

LED Kit with 16v Step Down Box

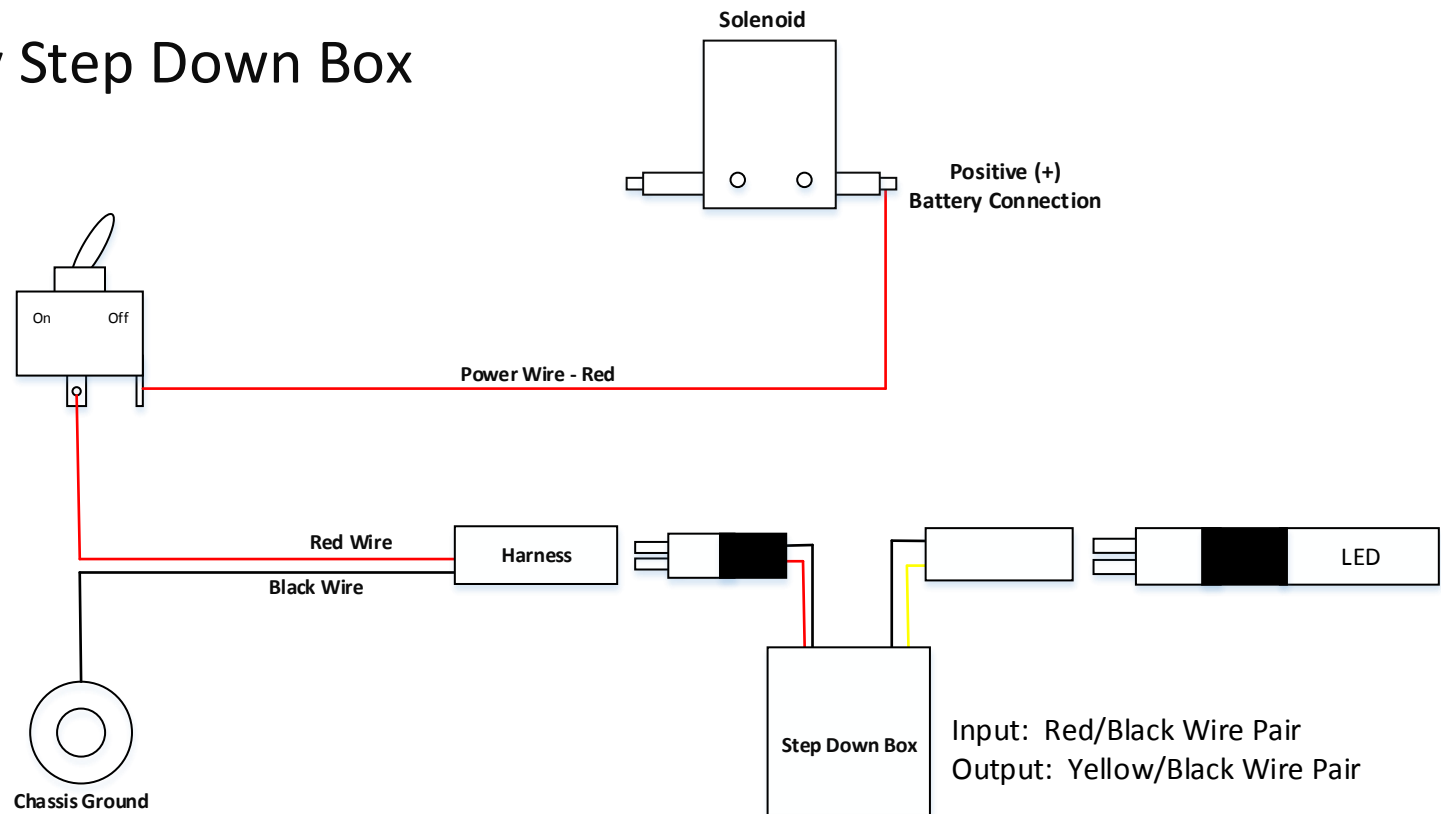

Instructions

1. Secure LED strip to chassis
2. Connect power wire to the toggle switch post. This post is the post the toggle is "pointing" to when in the Off position.
3. Connect red wire from harness to other toggle switch post.
4. Install switch.
5. Connect black wire from harness to chassis or battery ground.
6. Connect power wire from switch to positive post of solenoid or other battery connect.
7. Plug harness into male connector (red/black pair) on step down box.
8. Plug female connector (yellow/black pair) into the LED strip.

Off-Road Use ONLY

This product is for off-road use only. All modifications or installations are at the customer's own risk. LED Foot Products hold no responsibility either implied or otherwise for mechanical, electrical or other failure when using aftermarket products. Items sold for off-road use only are illegal in many states and provinces and are intended for racing vehicles which may never be used on a public road.

Warning

Installation of any component or kit should only be performed by persons experienced in the installation and proper operating of vehicle systems. It is also the responsibility of the person installing any component or kit to determine suitability and fitness of the components or kit for that particular application. The manufacturer is not responsible for any misuse.